

Penthouse (3-Bedroom + Study)

TYPE PH1

192 sq m / 2,067 sq ft
(including 30 sq m / 323 sq ft void)

BLK15 - #13-18

BLK25 - #14-48

BLK27 - #16-52

BLK33 - #15-70

TYPE PH1-1

162 sq m / 1,744 sq ft

BLK23 - #14-37*

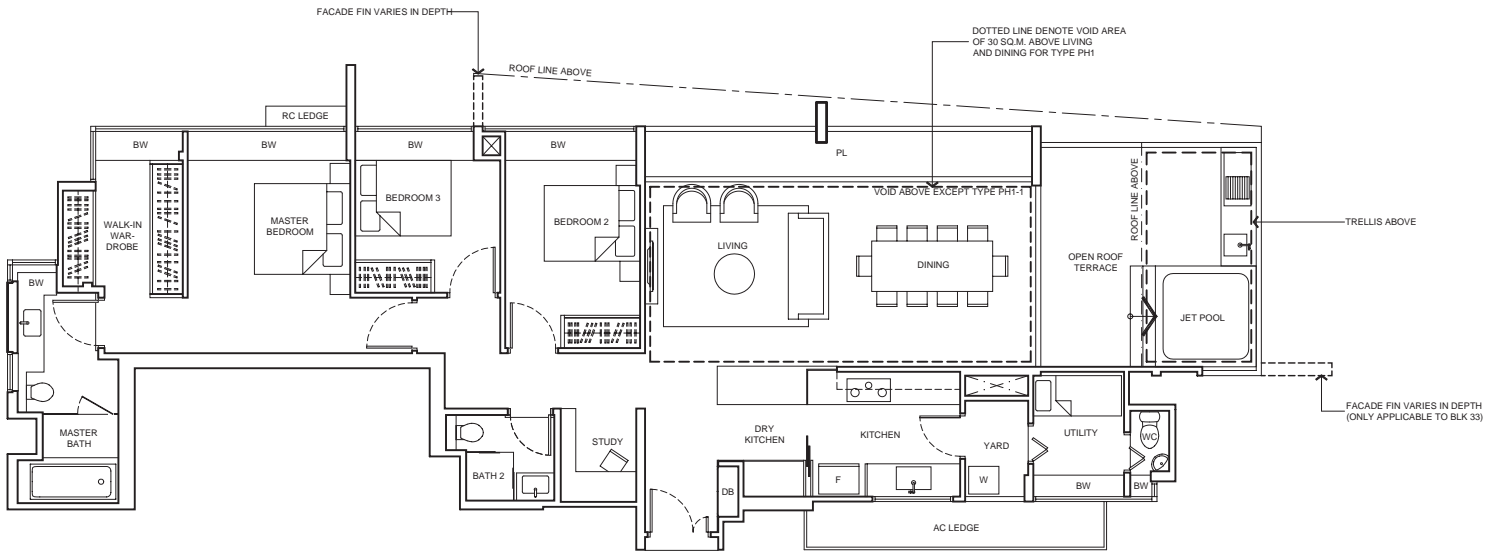

*mirror image unit

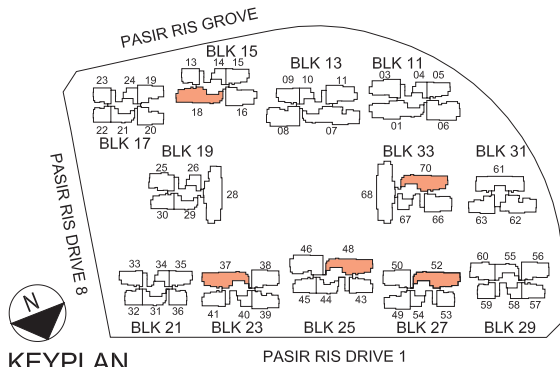

KEYPLAN
NOT TO SCALE

PASIR RIS DRIVE 1



Area includes air-con (AC) ledge, planter (PL), bay window (BW), private enclosed space (PES), open roof terrace and void area where applicable. Some units are mirror images of the apartment plans shown in the brochure. Please refer to the key plan for orientation. The plans are subjected to change as may be approved by relevant authorities. All floor plans are approximate measurements only and are subjected to government resurvey.

Penthouse (4-Bedroom)

TYPE PH2

200 sq m / 2,153 sq ft

(including 27 sq m / 291 sq ft void)

BLK31 - #16-61

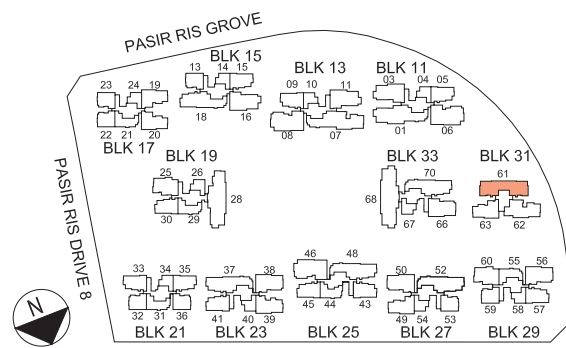
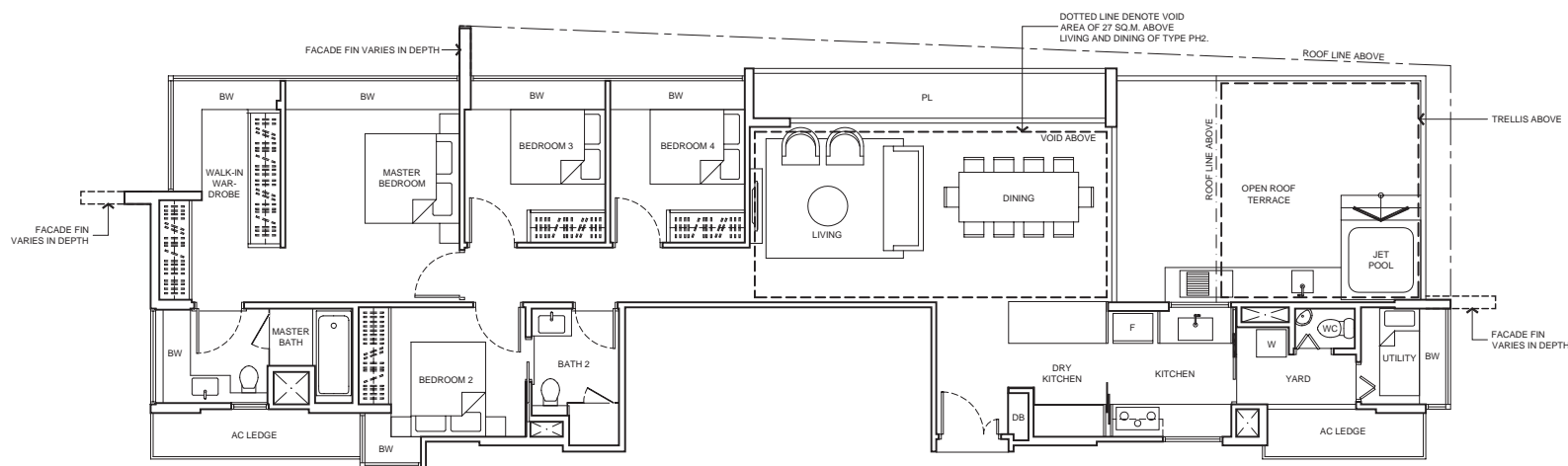

KEYPLAN
NOT TO SCALE

PASIR RIS DRIVE 1



Area includes air-con (AC) ledge, planter (PL), bay window (BW), private enclosed space (PES), open roof terrace and void area where applicable. Some units are mirror images of the apartment plans shown in the brochure. Please refer to the key plan for orientation. The plans are subjected to change as may be approved by relevant authorities. All floor plans are approximate measurements only and are subjected to government resurvey.

Penthouse (4-Bedroom)

TYPE PH3

199 sq m / 2,142 sq ft

BLK11 - #15-01

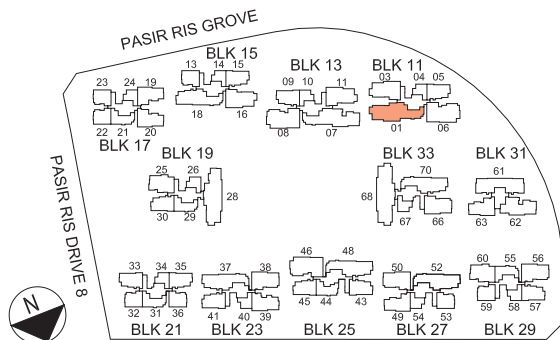
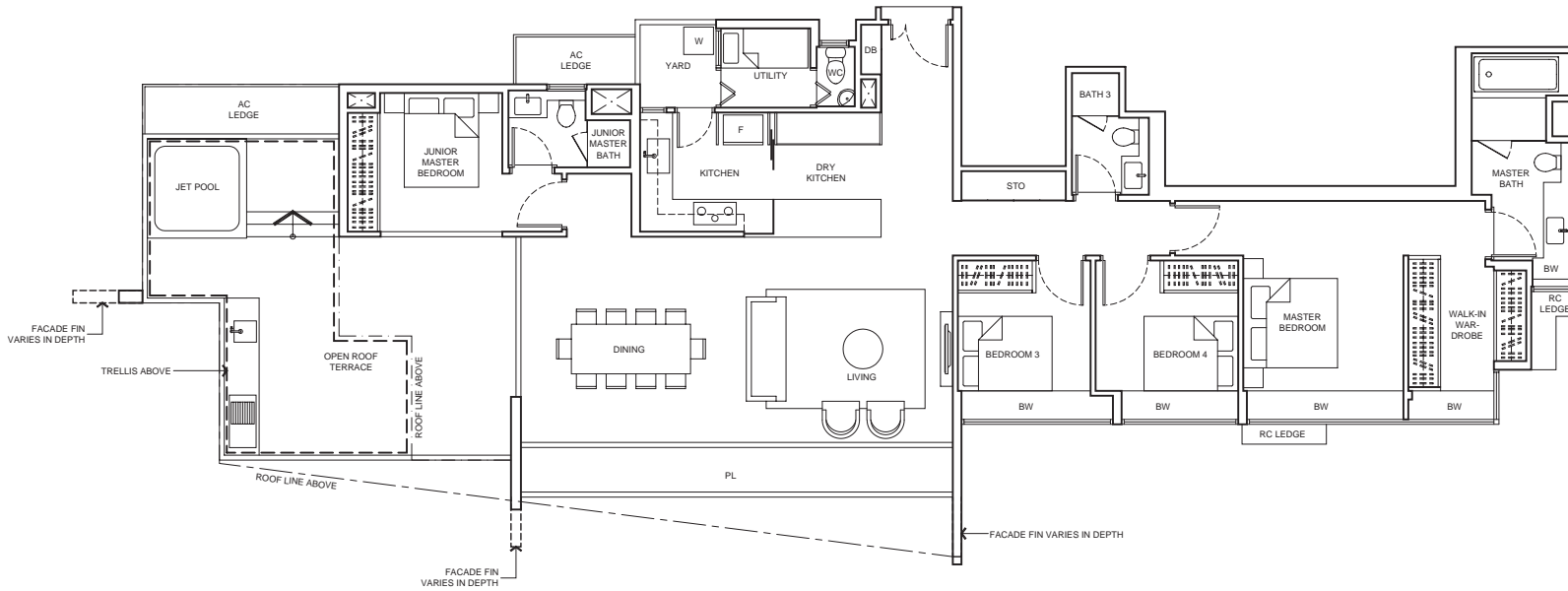

KEYPLAN
NOT TO SCALE

PASIR RIS DRIVE 1



Area includes air-con (AC) ledge, planter (PL), bay window (BW), private enclosed space (PES), open roof terrace and void area where applicable. Some units are mirror images of the apartment plans shown in the brochure. Please refer to the key plan for orientation. The plans are subjected to change as may be approved by relevant authorities. All floor plans are approximate measurements only and are subjected to government resurvey.

Penthouse (4-Bedroom)

TYPE PH4

234 sq m / 2,519 sq ft

(including 33 sq m / 355 sq ft void)

BLK13 - #14-07

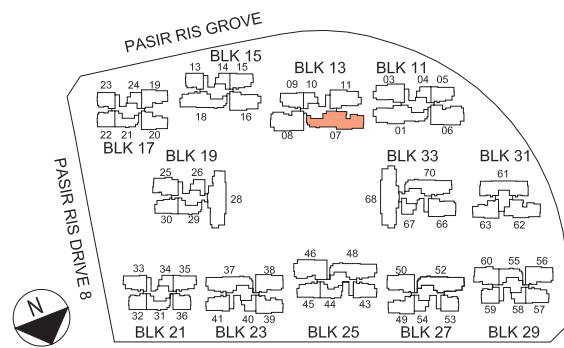
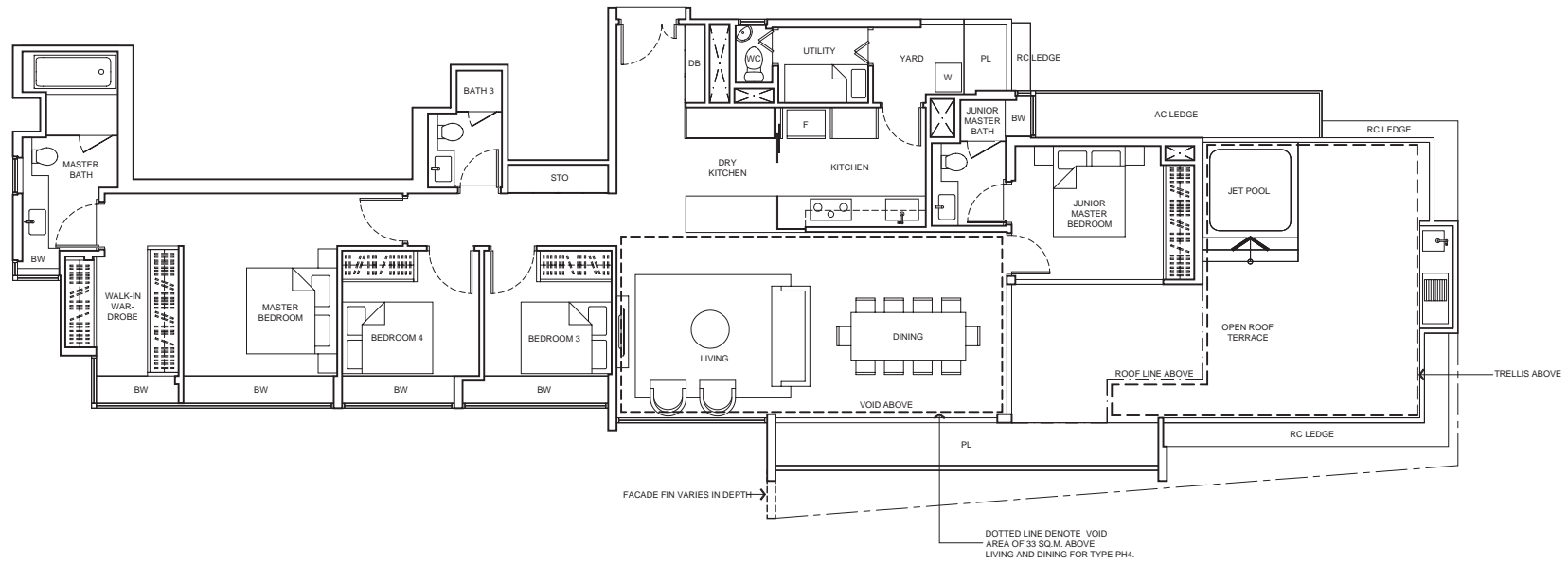

KEYPLAN
NOT TO SCALE

Area includes air-con (AC) ledge, planter (PL), bay window (BW), private enclosed space (PES), open roof terrace and void area where applicable. Some units are mirror images of the apartment plans shown in the brochure. Please refer to the key plan for orientation. The plans are subjected to change as may be approved by relevant authorities. All floor plans are approximate measurements only and are subjected to government resurvey.



Penthouse (5-Bedroom + Study)

TYPE PH7

272 sq m / 2,928 sq ft
(including 37 sq m / 398 sq ft void)
BLK19 - #13-28

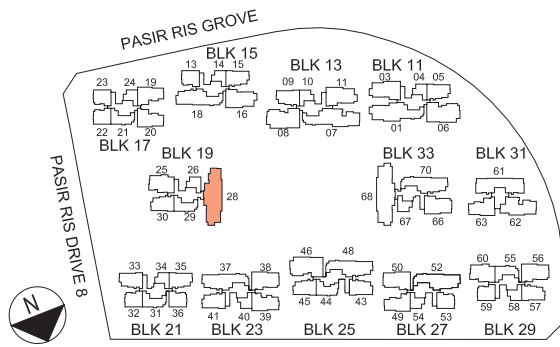
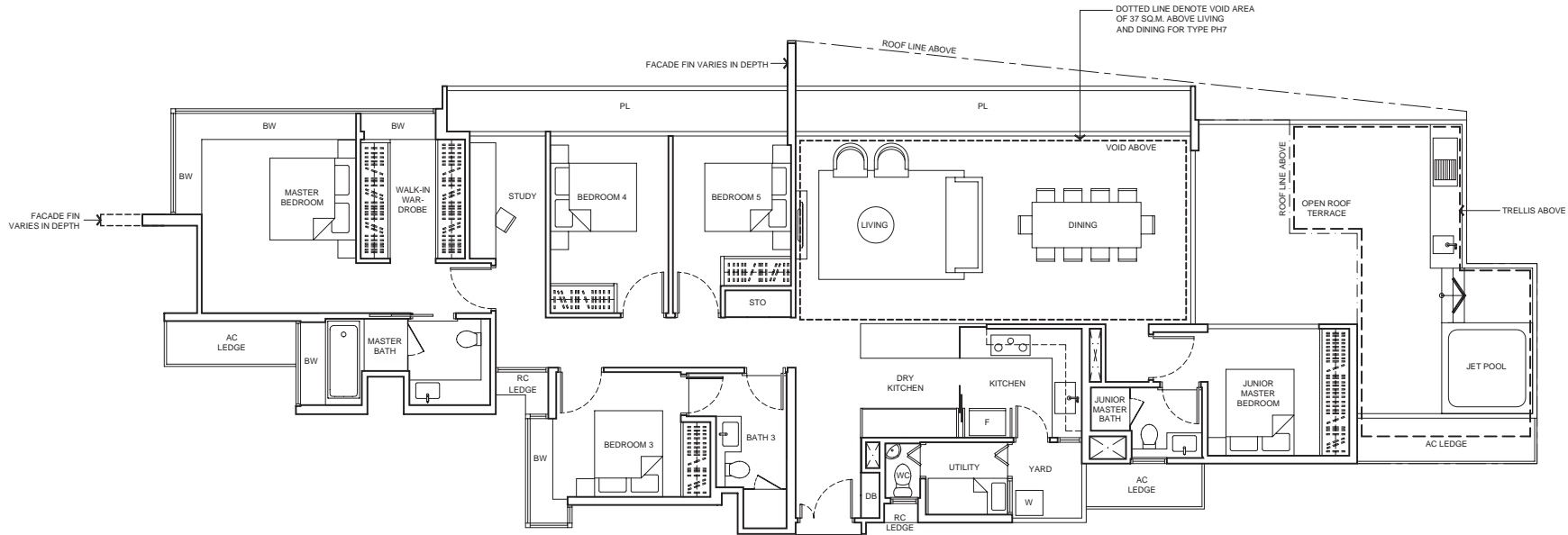

KEY PLAN
NOT TO SCALE

PASIR RIS DRIVE 1



Area includes air-con (AC) ledge, planter (PL), bay window (BW), private enclosed space (PES), open roof terrace and void area where applicable. Some units are mirror images of the apartment plans shown in the brochure. Please refer to the key plan for orientation. The plans are subjected to change as may be approved by relevant authorities. All floor plans are approximate measurements only and are subjected to government resurvey.

Penthouse (6-Bedroom)

TYPE PH10

289 sq m / 3,111 sq ft

(including 37 sq m / 398 sq ft void)

BLK33 - #15-68

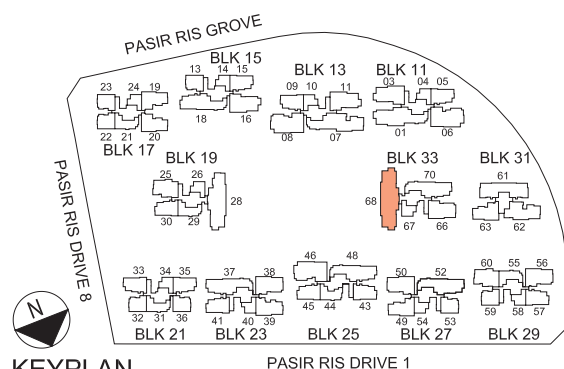
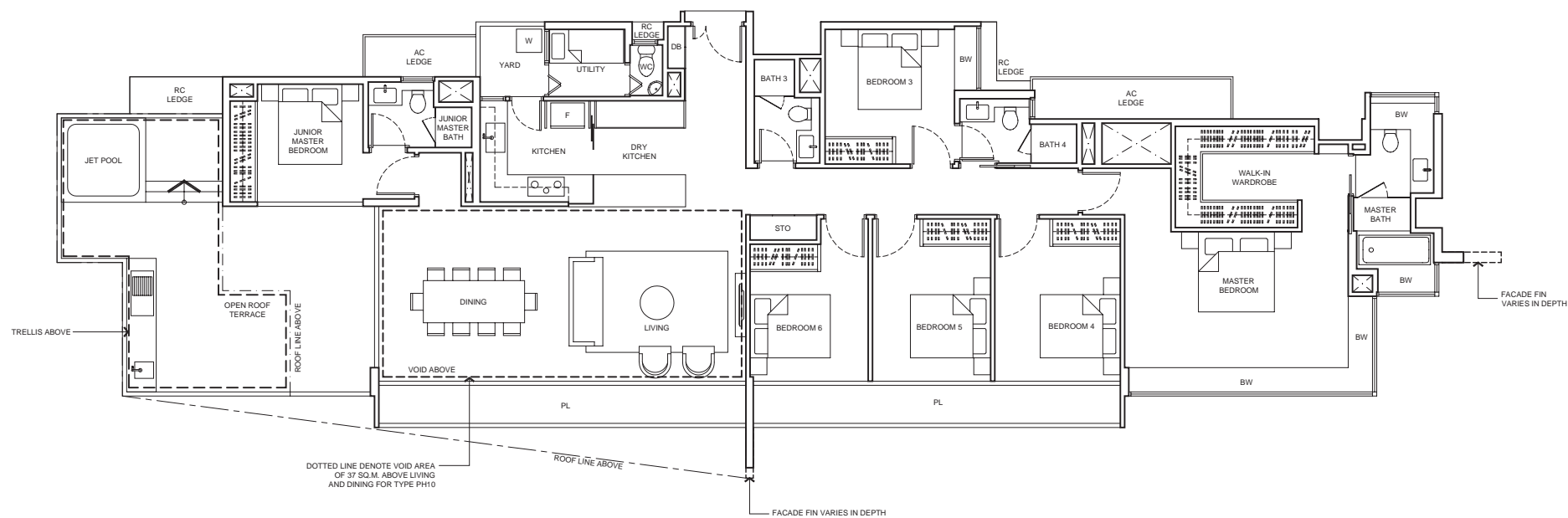

KEYPLAN
NOT TO SCALE

Area includes air-con (AC) ledge, planter (PL), bay window (BW), private enclosed space (PES), open roof terrace and void area where applicable. Some units are mirror images of the apartment plans shown in the brochure. Please refer to the key plan for orientation. The plans are subjected to change as may be approved by relevant authorities. All floor plans are approximate measurements only and are subjected to government resurvey.

