

3-Bedroom Dual Key

TYPE DK1 (P)
 145 sq m / 1,561 sq ft
 BLK29 - #01-60

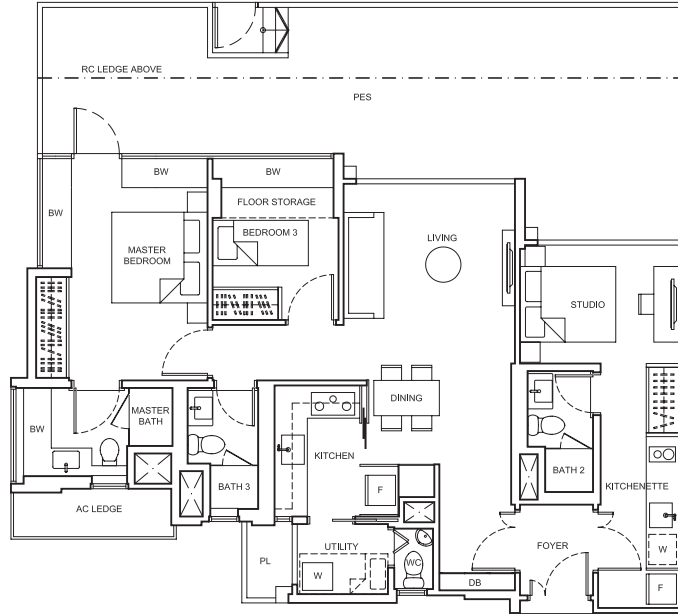

TYPE DK1
 107 sq m / 1,152 sq ft
 BLK19 - #02-25 to #13-25
 BLK29 - #02-60 to #16-60

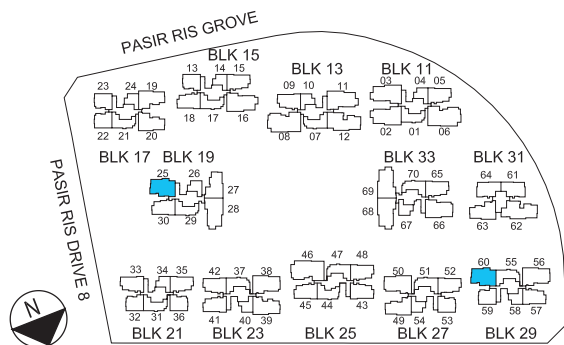
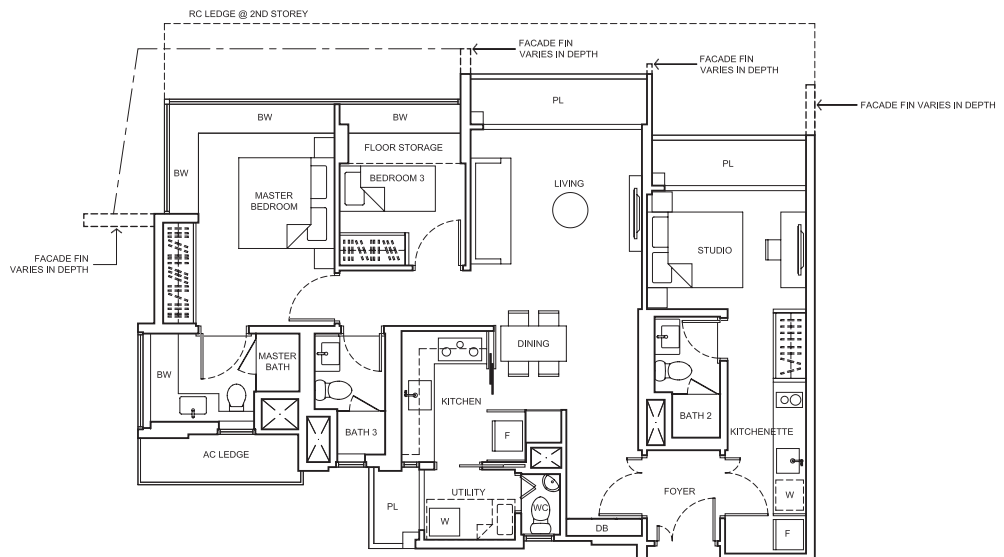

KEYPLAN
 NOT TO SCALE

Area includes air-con (AC) ledge, planter (PL), bay window (BW), private enclosed space (PES), open roof terrace and void area where applicable. Some units are mirror images of the apartment plans shown in the brochure. Please refer to the key plan for orientation. The plans are subjected to change as may be approved by relevant authorities. All floor plans are approximate measurements only and are subjected to government resurvey.

NOTE:
 - DEPTH OF PLANTER AND FLOOR STORAGE IS APPROX. 350mm FOR TYPE DK1 AT BLK29 - #02-60

3-Bedroom Dual Key

TYPE DK2 (P)
 143 sq m / 1,539 sq ft
 BLK19 - #01-25

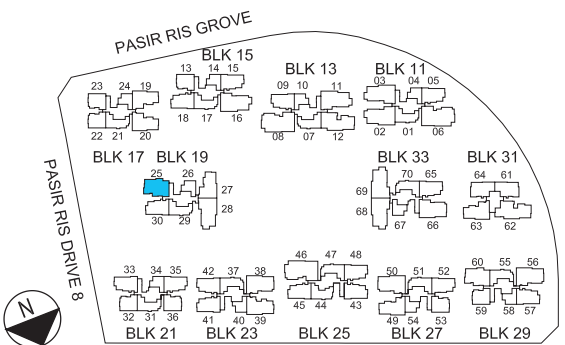
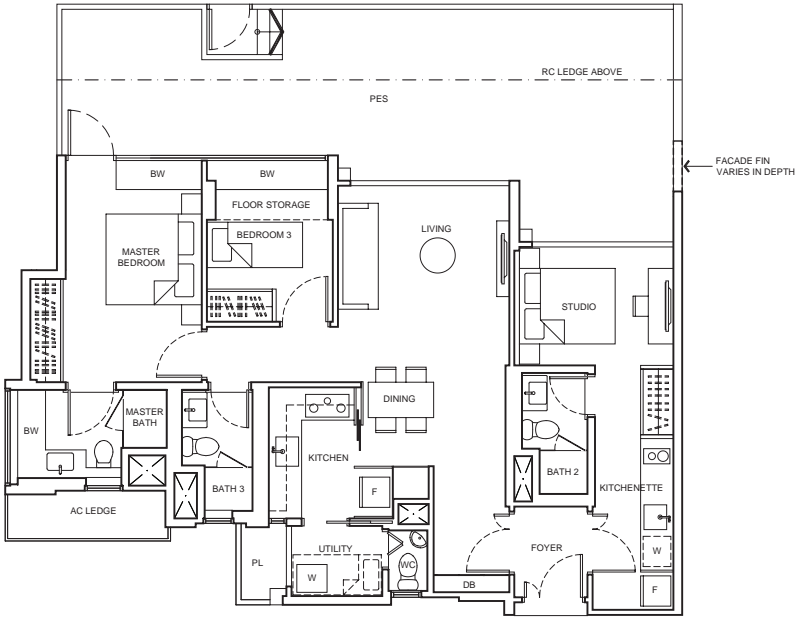

KEYPLAN
 NOT TO SCALE

Area includes air-con (AC) ledge, planter (PL), bay window (BW), private enclosed space (PES), open roof terrace and void area where applicable. Some units are mirror images of the apartment plans shown in the brochure. Please refer to the key plan for orientation. The plans are subjected to change as may be approved by relevant authorities. All floor plans are approximate measurements only and are subjected to government resurvey.

